

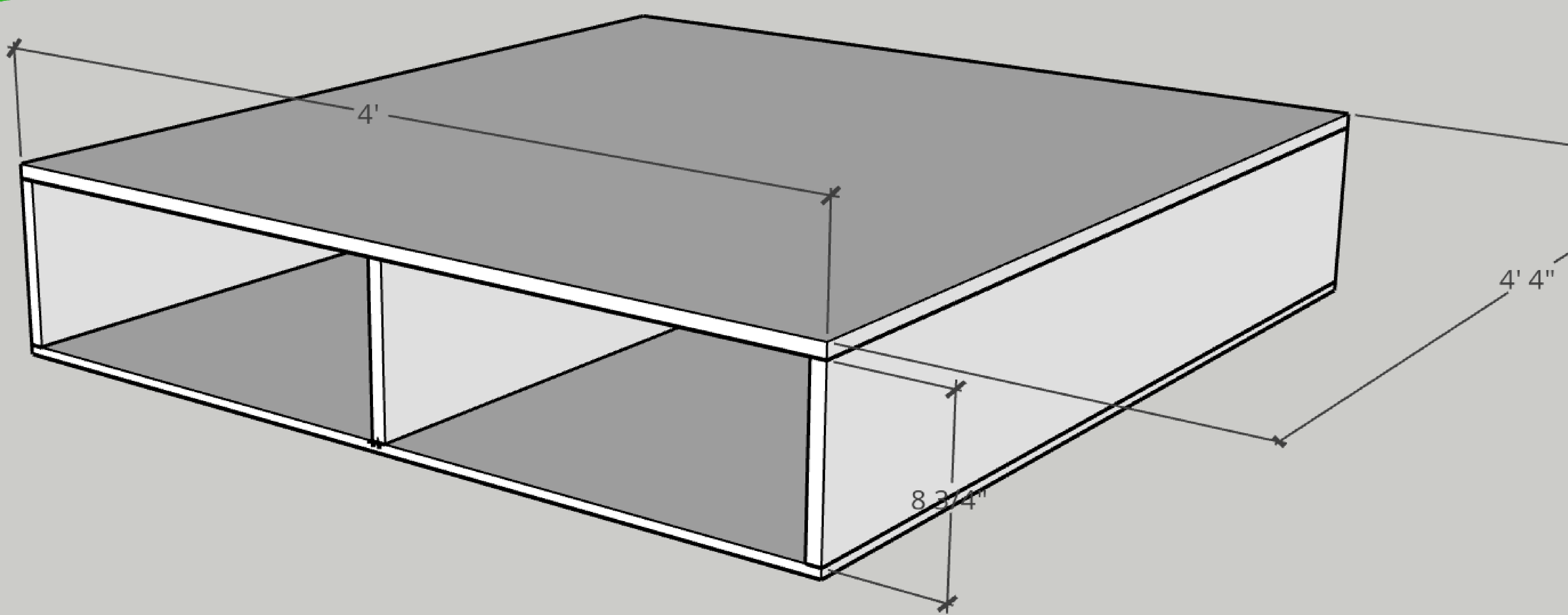

DUALEX BUILDS



THE FRAME



The vertical supports and top of the frame is made out of 3/4" Plywood.

The bottom of the frame is 1/2" plywood in order to save on weight. In the final build I used slats on the bottom to save even more weight.

KITCHEN DRAWER

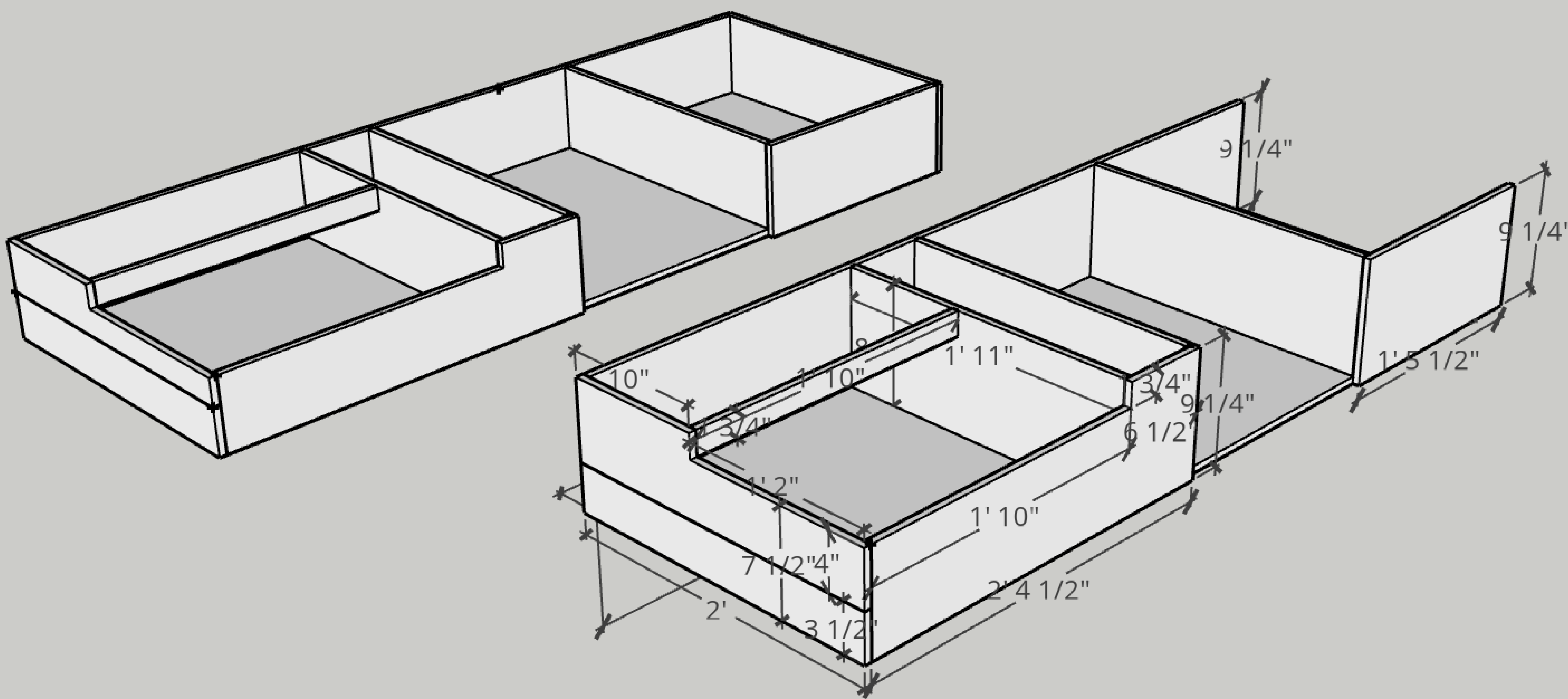

The 3d model on the left shows how the drawer should look assembled.

The model on the right is the same model with the dimensions visible.

There is a lot going on in this drawer build, so make sure you check out the sketchup file to get a closer look at each one of these parts.